

Direct Lifts Australia

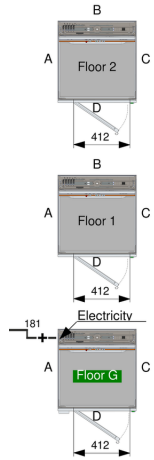

G - Glass
S - Sandwich

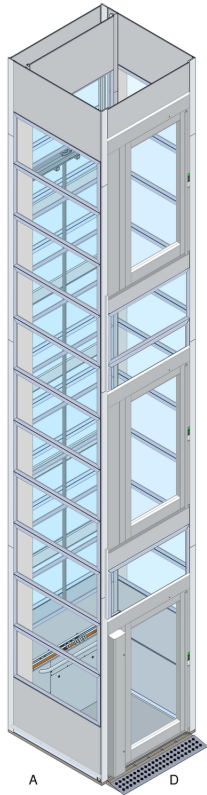
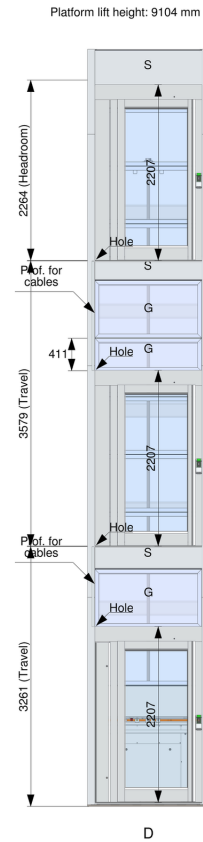
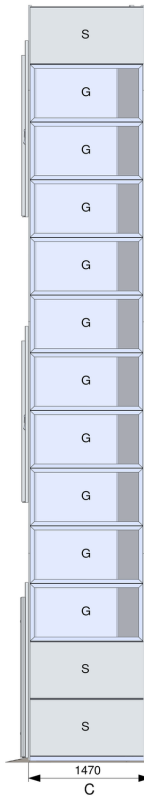
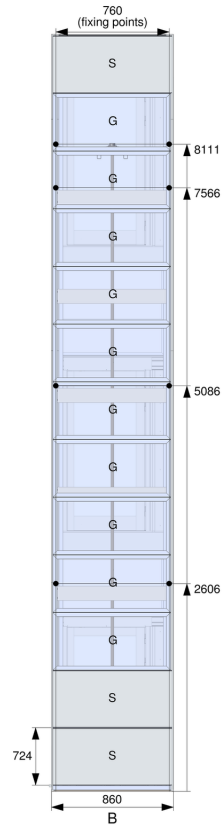
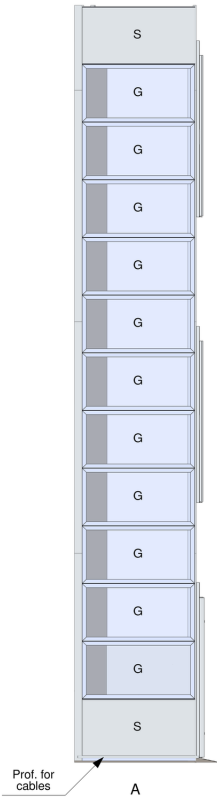

Technical specifications:

System: screw-driven
 Rated load: 250 kg
 Speed: 0.15 m/sec
 Platform dimensions: 1080 x 805 mm
 Shaft dimensions: 1470 x 860 mm
 Floor slab hole: 1510 x 900 mm
 Travel: 6840 mm
 RAL 9010 (painted)
 3 stops
 Power supply 220 V, 1 phase, 50 Hz, C25
 Frequency converter: Included
 Keyboard language: English
 Application: Internal

Remarks:
 Electricity 3 x 4 mm2

Door:
 3 Aluminum with glass (standard) door 412 x 2000 (left, Manual (standard))
 Ramp (1 pcs.)

Additional equipments:

Telephone on the platform
 Reinforced guide rails
 Automatic emergency lowering
 One touch operation
 Packaging on the heated wood pallets
 Logo on the control panel: Only Client logo
 Control panel strip color: Silver

Serial no	Principal drawing 1080 x 805 mm
Order no	
Date	



Direct Lifts Australia

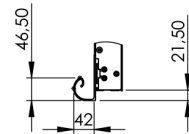
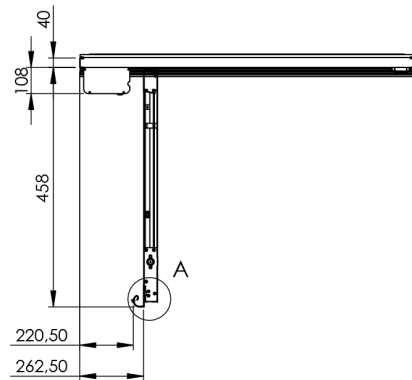
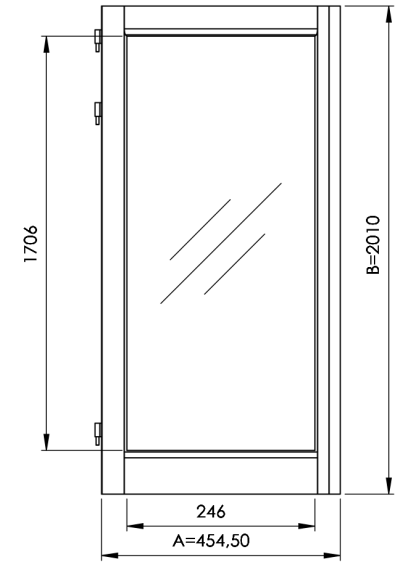
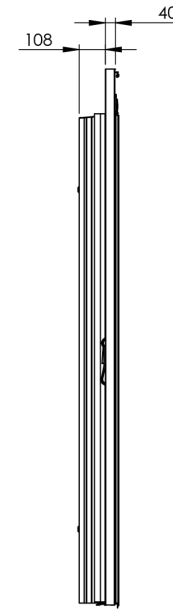
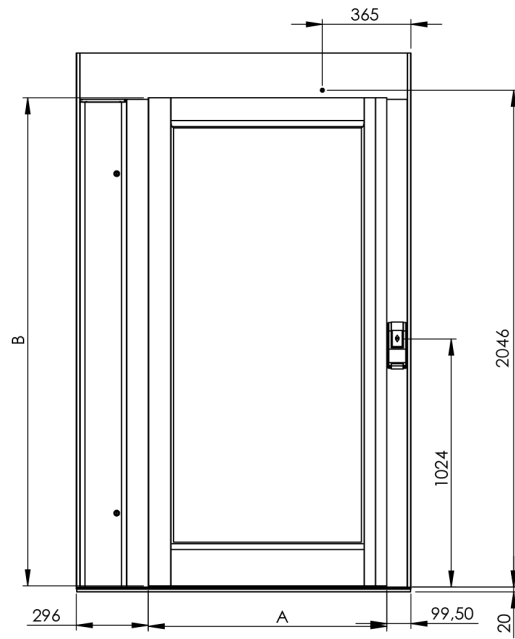
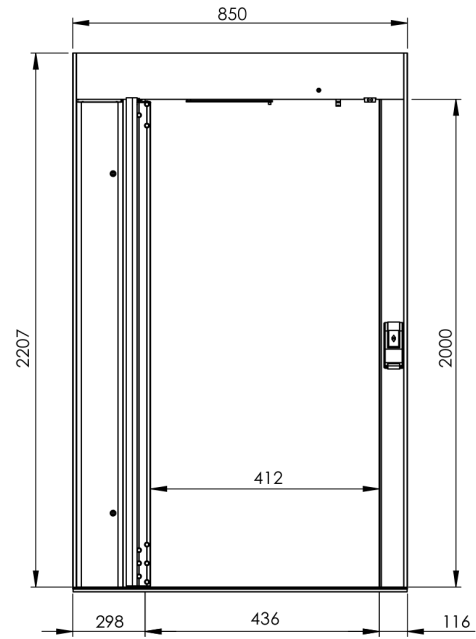

Selections:
Ramp

Serial no	Principal door drawing Floor G, side D K.p.k.-AD
Order no	
Date 2020-06-29	

Direct Lifts Australia

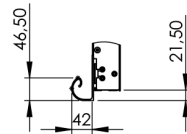
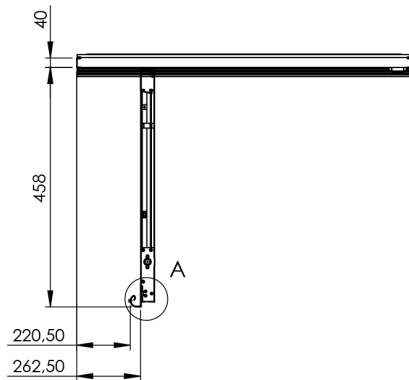
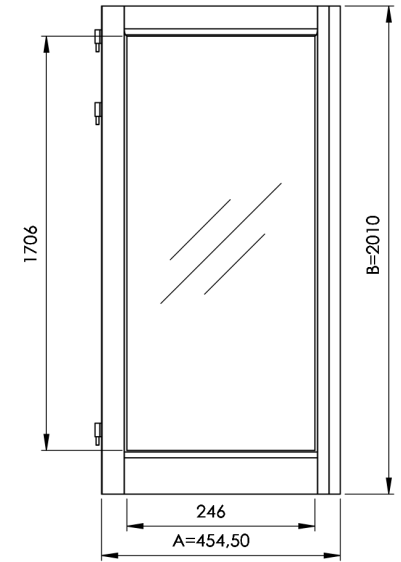
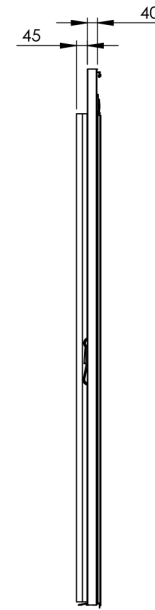
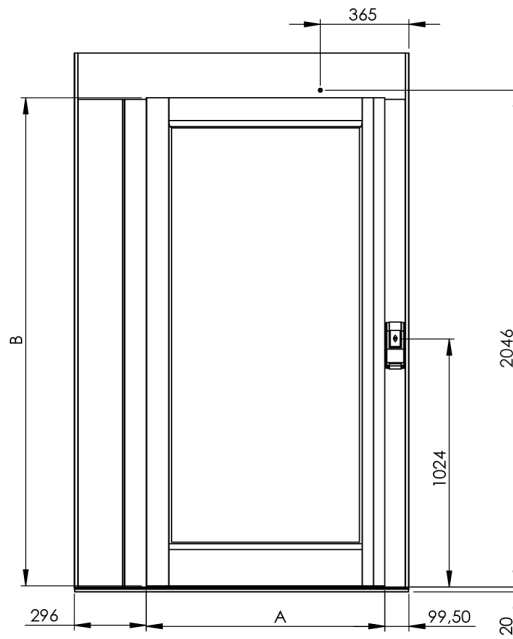
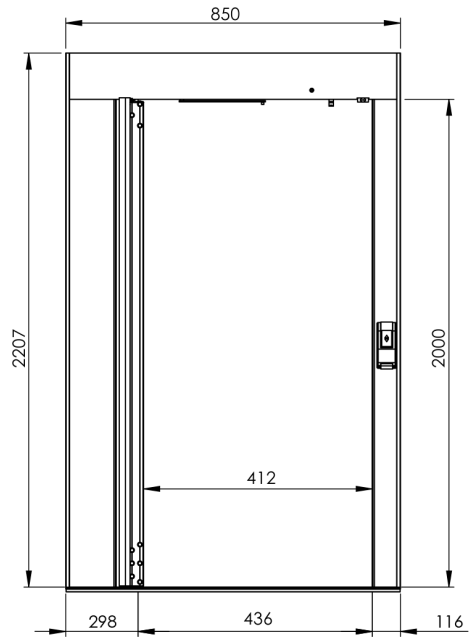

Selections:

	Serial no	
	Order no	
	Date	

Direct Lifts Australia

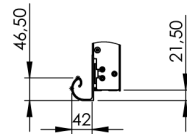
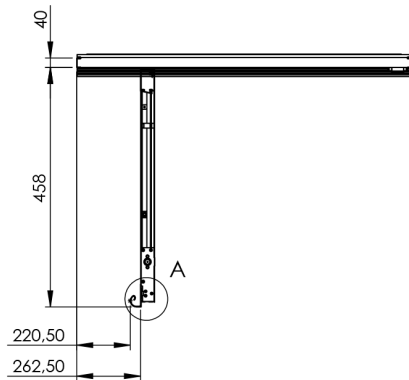
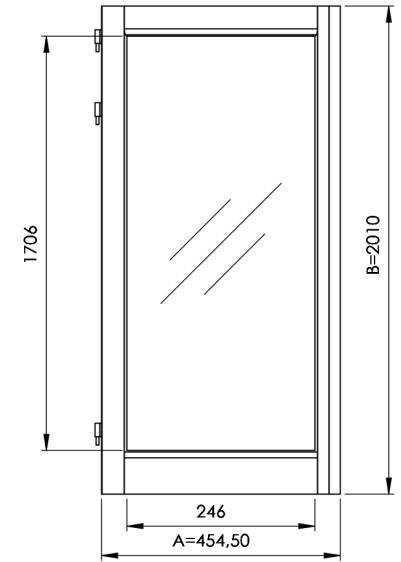
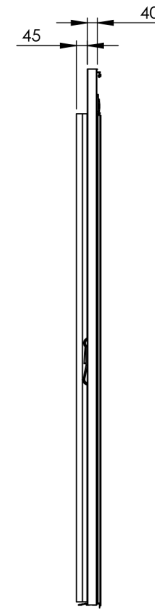
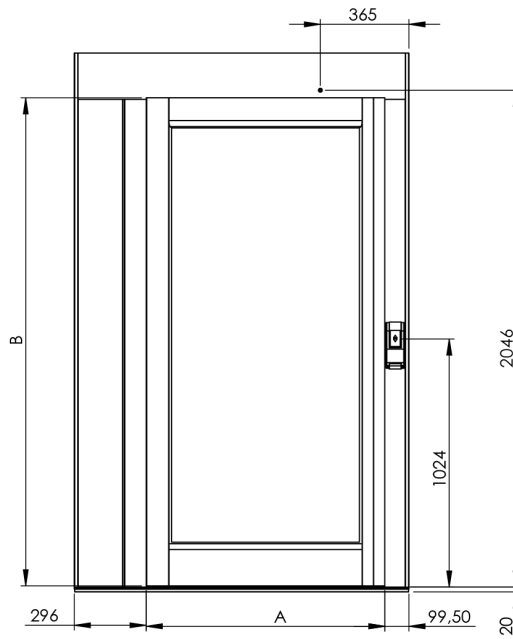
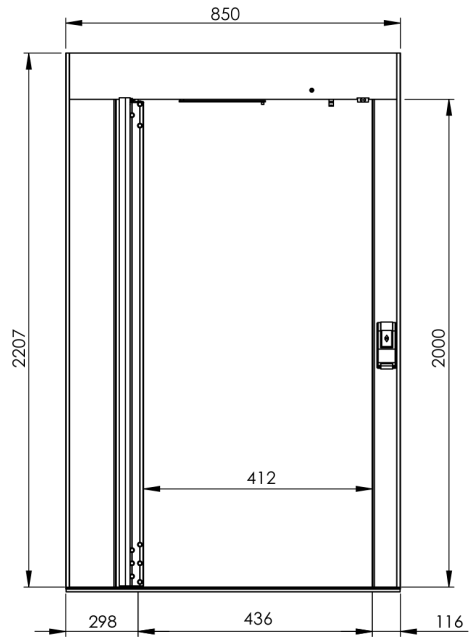

Selections:

	Serial no	
	Order no	
	Date	