

Technical specifications:

System: screw-driven
 Rated load: 400 kg
 Speed: 0.15 m/sec
 Platform dimensions: 910 x 1325 mm
 Shaft dimensions: 1300 x 1380 mm
 Footprint dimensions: 1340 x 1420 mm
 Pit 50 mm
 Travel: 3380 mm
 RAL 9006 (anodized aluminum)
 Glass color of panel: Planibel Grey
 3 stops
 Power supply 220 V, 1 phase, 50 Hz, C25
 Frequency converter: Included
 Keyboard language: English
 Application: Internal

Remarks:
 Load - 13.7 kN/m2.
 Electricity 3 x 4 mm2

Door:
 2 Aluminum with glass (standard) (glass color: Planibel Grey) door 884 x 2300 (left, Manual (standard))
 1 Aluminum with glass (standard) (glass color: Planibel Grey) door 888 x 2000 (right, Manual (standard))

Additional equipments:
 Ceiling with light (LED Spots)
 Telephone on the platform
 Reinforced guide rails
 One touch operation
 Packaging on the heated wood pallets
 Other platform floor cover (Light timber look vinyl)
 Logo on the control panel: Only Client logo
 Control panel strip color: Silver

Serial no	Principal drawing Flex-e 910 x 1325 mm General
Order no	
Date	

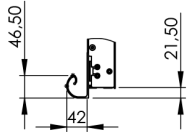
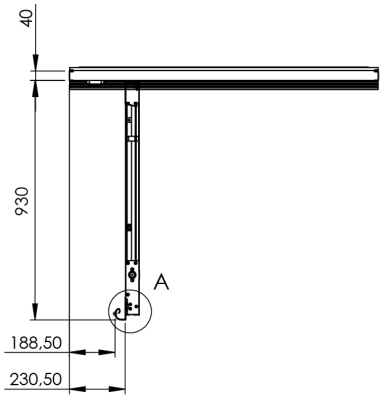
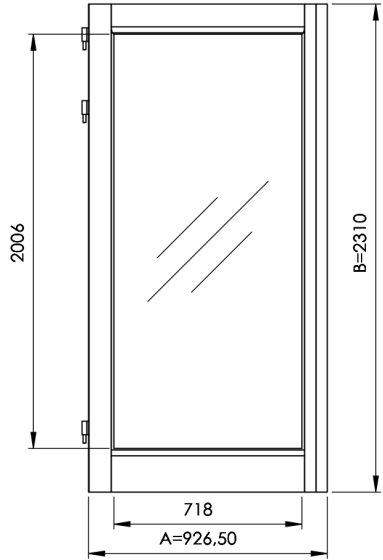
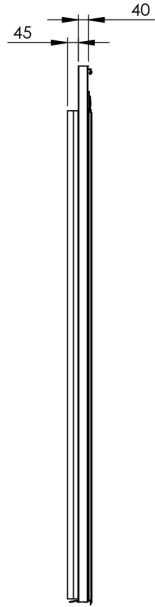
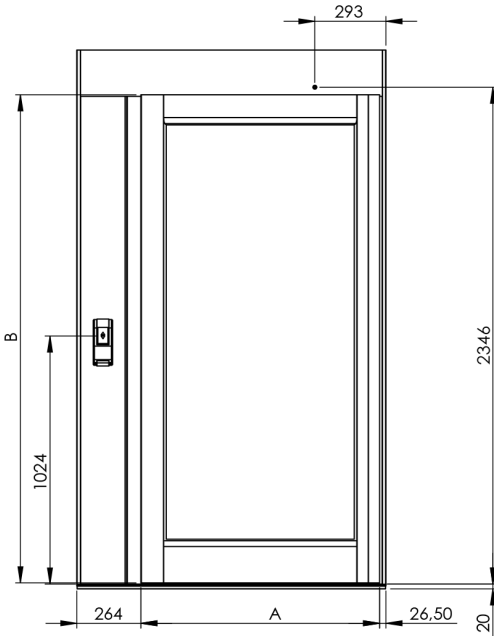
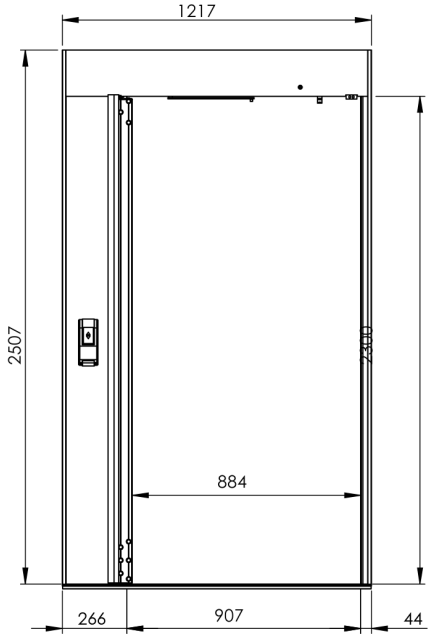

Selections:

	Serial no	
	Order no	
	Date	

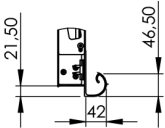
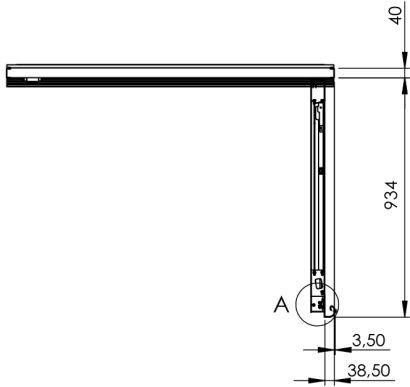
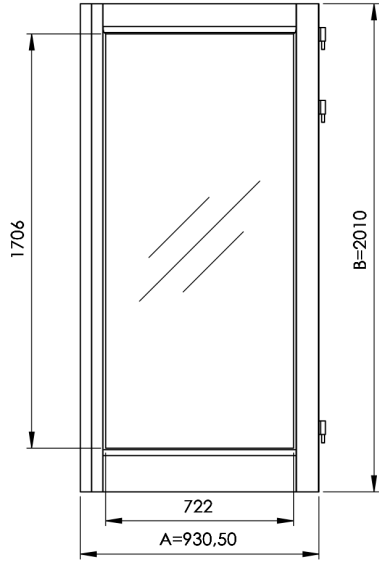
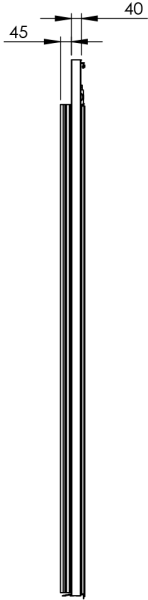
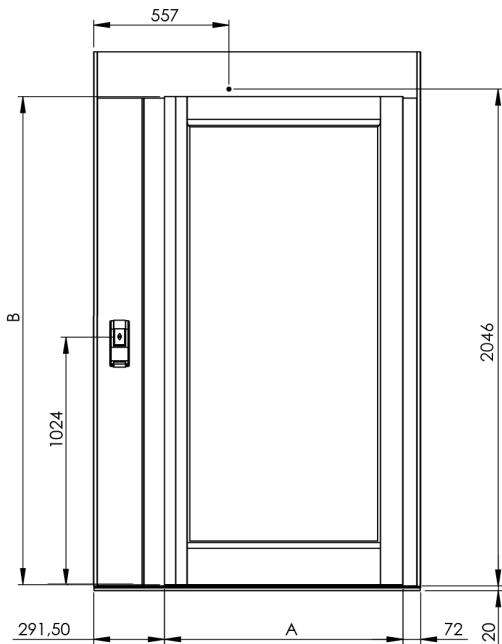
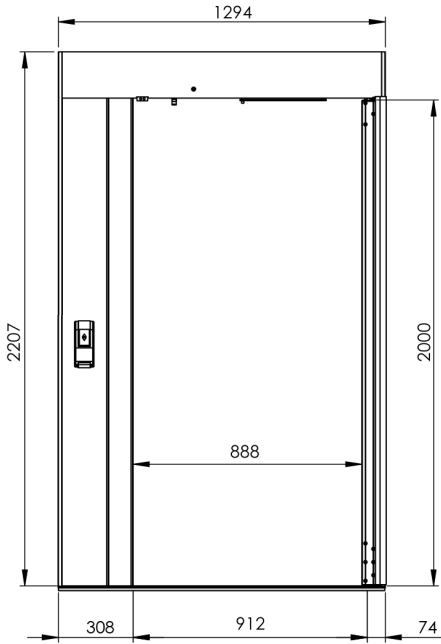

Selections:

	Serial no	
	Order no	
	Date	

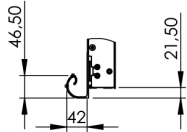
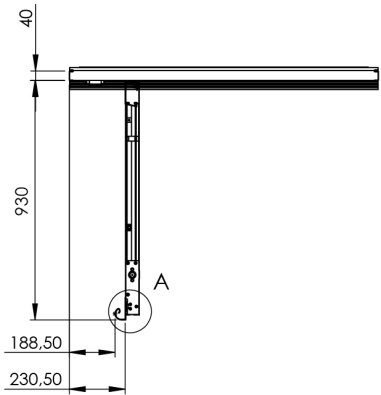
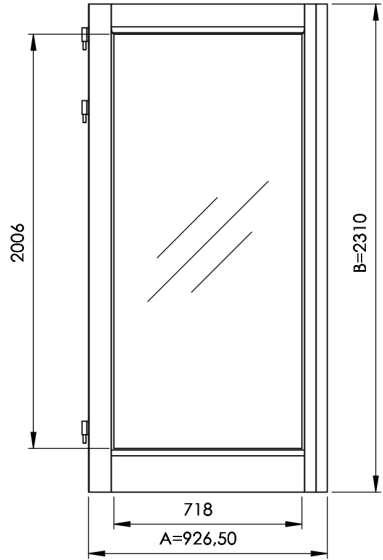
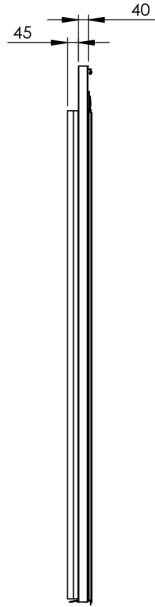
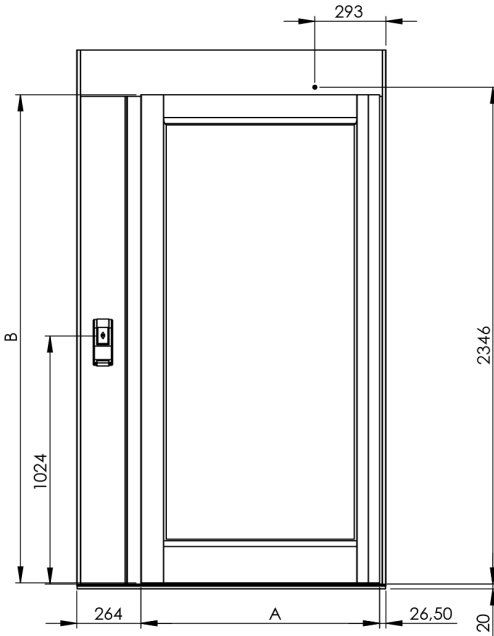
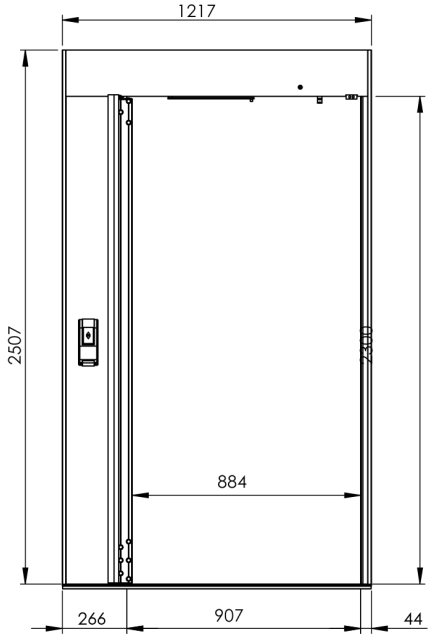

Selections:

	Serial no	
	Order no	
	Date	