



LEVANT

Stair Chair Lift

Safe & affordable way to stay in your home longer

Delivers a solution for all indoor and outdoor straight staircase requirements and budgets.

146 kg
rate load

5 meters
travel height

1-person
capacity

2-stops
landings

manual or swivel
seat configurations



Levant Classic Stairlift

For straight staircases

The Levant Classic Stairlift range delivers a solution for all indoor and outdoor straight staircase requirements and budgets. The Levant stairlift is fitted onto your staircase and not your wall. This allows the lift to be installed quickly, easily and with minimal disruption to your home.

The Levant is designed to glide effortlessly along an aluminium track, providing an attractive, elegant and discreet addition to your home. Built using the latest technology, the Levant range can be fitted to almost all straight staircases as narrow as 740 mm.

1 It's All About You

The thick and luxurious padding ensures a firm and comfortable seat. The upholstery is in a neutral tone - sisal, that will fit with any decor style. The upholstery is also fire retardant, liquid repellent and easy to clean. The Levant stairlift is operated with an easy to use joystick which can also be removed to prevent unauthorised usage.

2 Compact & Discreet

The Levant design is simple, sturdy and above all satisfies your accessibility requirements. Remote control handsets allow the Levant to park at either the top or bottom of the staircase, wherever is the most convenient for you. When not in use the Levant stairlift is folded away to only 380 mm on any landing, out of the way of any other staircase users.

3 Safety

Your safety is of paramount importance to us. The Levant stairlift is certified to machine directive 2006/42/EG and it is also compliant with Australian Standard AS1735.7. During travel the retractable seat belt will keep you secure on the stairlift. If the lift encounters an obstacle it will safely come to a stop as a result of special safety edges on the drive unit. The stairlift is battery operated, which means you can still use it during a power cut.





The Levant's aluminium rail has a slim design giving a modern and clean look.



I just love my Levant stairlift! I had real difficulties climbing the stairs, but now I just sit in comfort on the stairlift, no more problems."



Optional Extras | Levant Classic

A Levant stairlift is the ideal solution for your staircase. With a smooth aluminium track, this stairlift can be fitted to almost any straight staircase.



Maximum Weight

As standard the Levant will support weights of up to 146 kg.

Move between all levels of your home with maximum comfort and safety.





Levant Outdoor Stairlift

Resistant to harsh weather elements

Durable in all weather conditions, the Levant Outdoor provides a solution for any straight outdoor staircase. The Levant Outdoor has been thoroughly tested to ensure it can withstand the varied conditions across the Australian landscape.



Design features to ensure longevity include:

- Chair, drive unit and joystick are waterproof
- Rail is made of anodised aluminium and uses stainless steel screws
- Covered side positioned rack to prevent leaves and other debris catching with the carriage
- Folding waterproof seat
- Waterproof cover fully covers the lift and provides protection from the elements.



Safety belt



Waterproof UI & key switch



Double sided swivel

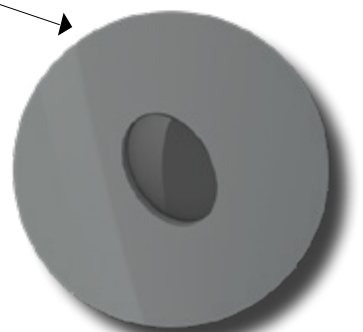

Call & send IR receiver

The infrared call & send stations mean the stairs are completely free of cable and wires and provides a nice clean installation. The Levant Outdoor is operated by a joystick that also functions as a key, allowing you to lock the lift whilst not in use.

With a maximum user weight of 146kgs, the Levant Outdoor allows you access to your home as well as the ability to continue to enjoy the beautiful outdoor areas your home has to offer.

Levant Classic & Outdoor | Technical specifications

Capacity

146 kg (inclination between 28° and 45°)

127 kg (inclination between 46° and 53°)

Operation

Battery (24 V cc)

Rails

Rack and pinion drive system
Extruded anodized aluminium

Speed

Max 0,12 m/s

Inclination

Between 28° and 53°

Power Requirements

Power supply 220/240 Volt, 2 dry batteries 12 Volt, 7A/h

Application

Straight single flight of stairs with constant gradient

Commands

Wireless controls, joystick which functions as a key, 2 battery operated wireless call & send stations on top & bottom of the stairs, radio frequency of 866 Mhz

Safety devices

Anti-crush sensors in the event of obstacles on the stairs

Installation

On the steps of the stairs

Optional

Hinged rail

Compliance

CE, AS 1735.7

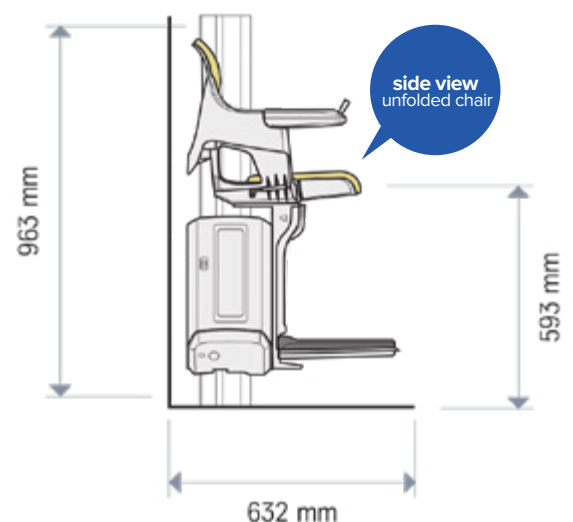
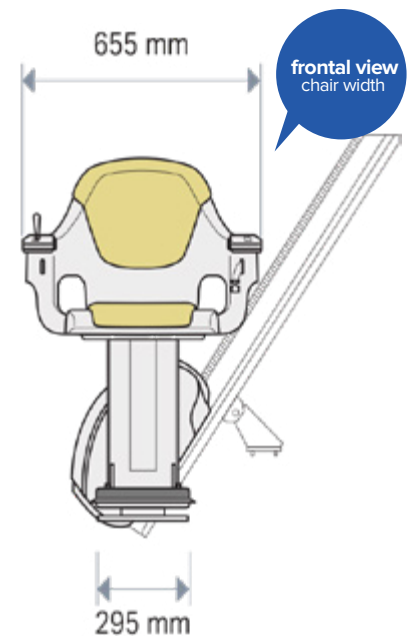



More Than A Decade Of Pride & Excellent Service

We are passionate about providing a high-quality stair lifts and mobility solutions to improve everyday lives.

We have our offices in Sydney, Coffs Harbour, Brisbane and affiliated partners across Australia to handle the demand for our services.

Our team of professionals will be with you throughout the entire process, starting from the quotation, installation, and up to handover and after-sales support.

They will handle everything in between to ensure that your lift is equipped with everything it needs for years to come.

4.8 STAR RATING



DIRECT LIFTS
AUSTRALIA

We're so proud to say that our **4.8 star rating** on Google is proof of excellent service and top-tier installation.



SCAN & WATCH
THE LEVANT VIDEO

Contact us today and speak with our professional lift experts to discuss the best options & deals available.

1300 240 298

info@directlifts.com.au

NEW SOUTH WALES ■ QUEENSLAND ■ VICTORIA

www.directlifts.com.au